

UNIVERSAL DISPLAY MODULE

MODEL UDM-001 / UDM-002



UDM-002

Operator's Installation and Instruction Manual

Protek Safety & Controls Ltd.
#10, 1715 – 27th Ave NE
Calgary, AB T2E 7E1
Ph.403-668-6869 / Fax 403-668-6865
www.proteksc.com

Table of Contents

1. Introduction.....	1
1.1 Features.....	1
1.2 Compatible Gas Detectors.....	1
2. Safety Guidelines for Safe Use.....	2
3. Installation.....	3
3.1 Mounting.....	3
3.2 Field Wiring.....	3
4. Startup / Configuration.....	5
4.1 Startup.....	5
4.2 Operator Interface.....	5
4.3 Magnetic Programming Tool.....	5
5. Operational Menus.....	6
5.1 Normal Operation.....	6
5.2 Fault Mode.....	6
5.3 Settings / Program Mode.....	7
5.3.1 View Sensor Status Menu.....	7
5.3.2 Set Autospan Level Menu.....	8
5.3.3 Turning the Display OFF & ON.....	9
5.3.4 Service Menu.....	10
5.3.4.1 View Comm Error.....	10
5.3.4.2 Restore Sensor Defaults.....	11
5.3.4.3 View Event Logs.....	11
5.3.4.4 Erase Event Logs.....	12
5.4 Calibration Mode (Zero & Span).....	17
5.4.1 Zero Calibration.....	17
5.4.2 Span Calibration.....	17
6. Maintenance and Service Personnel Activities.....	18
7. Troubleshooting Guide.....	18
7.1 General Troubleshooting.....	18
7.1.1 Communication Fault (COMM Fault).....	18
7.2 Detcon Sensor Specific Troubleshooting.....	18
8. Specifications.....	22
9. Customer Support and Service Policy.....	23
10. Warranty Notice.....	23
11. Revision Log.....	24

List of Figures

Figure 1: Mounting Details.....3
Figure 2: UDM-Wiring Diagram4
Figure 3: Programming Magnet.....5
Figure 4: SEC Millenium Series Programming Flowchart.....13
Figure 5: SEC 3000 Series Programming Flowchart.....14
Figure 6: Detcon 700 Series Programing Flow Chart.....15
Figure 7: UDM-Service Menu Programing Flow Chart.....16
Figure 8: Detcon Sensor Specific Troubleshooting.....18
Figure 9: Sensor Electronics Corp Sensor Specific Troubleshooting....19

1. Introduction

1.1 Features

The Universal Display Module is a single or dual channel remote display module designed to achieve remote sensor separation for up to two gas detectors. It is designed to be universal across multiple brands of gas detection allowing the user to interact with the same interface but utilize the best technology for the application within those compatible brands. The UDM is provided in an epoxy painted explosion-proof enclosure with a viewing window.

The UDM display allows the 4-20mA output signal to pass directly through from the attached gas detector on each channel and does not interrupt or re-create the 4-20mA signal. The UDM acts as a digital communication master to each attached gas detector and displays the concentration, plus is as an interface to access the gas detectors menu structure for calibration and various parameter configurations.

1.2 Compatible Gas Detectors

Below is a list of compatible gas detectors at the time of this manual release.

- Detcon 700 series including FP700, DM700 (except DM-700-O2), IR700, TP700
- Sensor Electronics Millenium & Millenium Hawk Series
- Sensor Electronics SEC3000 Series

Additional parameters may be found by accessing each detector directly depending on the make and model of the gas detector connected.

The latest version of this manual and all compatible gas detector manuals can be found by using the left QR code link:

The latest YouTube tutorials and instructional videos can be accessed by using the right QR code link:



Manual



YouTube

2. Safety Guidelines for Safe Use

If equipment is used in a manner not specified in the manual, the protection provided by the equipment may be impaired. It is mandatory to read and follow all the Safety Warnings and Cautions listed below and throughout the manual.



Warning

- When installed in a Class 1, Div 1 / Zone 1 area, seals are required as per the certification label.
- When installed in a Class 1, Div 2 / Zone 2 area, seals are NOT required as per the certification label.



Warning

- Explosion Hazard. Do not open the enclosure or make any disconnections while the circuit is live or unless the area is known to be free of ignitable concentrations.
-

3. Installation

3.1 Mounting

The UDM series can be installed as a wall mount using the mounting tabs of the explosion-proof junction box. Once mounting of the enclosure is complete, the UDM PCB can be oriented on the square pattern stand-offs to ensure the OLED display is horizontal for viewing.

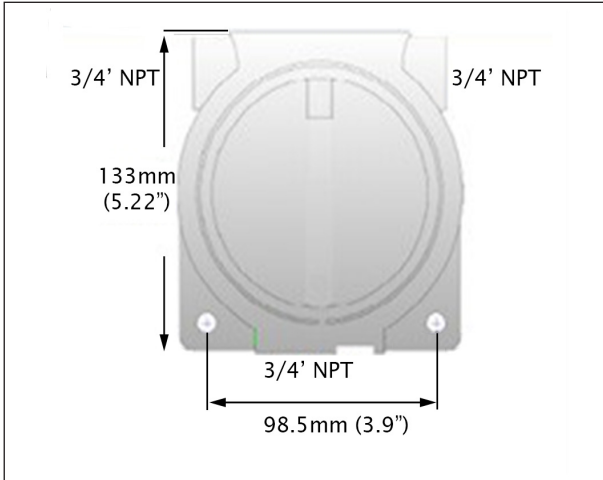

Figure 1: Mounting details

The UDM electronics display package consists of one PCB stack and a top graphics plate with two captive thumb screws to allow for removal of the PCB assembly from the enclosure. To install the electronics package, ensure power is off, properly align and hand tighten the captive thumb screws onto the horizontal standoffs in the enclosure. Next, install the enclosure cover.

3.2 Field Wiring

The field wiring connections are made to the bottom of the UDM PCA using removable terminal blocks. There are three 6-pin terminal block on the bottom of the PCA, Sensor #1, Sensor #2 (if applicable), and Power / Output connections as shown in Figure 2.

If remote sensor separation is required, the UDM can be separated from the gas detector. Remote separation distances of up to 1000 feet are possible with the recommended cables.

The recommended cable for remote sensor separation is Belden 8770 (18AWG shielded 3-wire cable) for connection of power and mA signal return and Belden 9841 (24AWG shielded twisted pair) for serial Modbus™ or digital communications.

NOTE: It is highly recommended to install the interconnecting cabling inside rigid metal conduit to eliminate potential EMI and RFI interference.

UNIVERSAL DISPLAY MODULE - SENSOR SEPARATION WIRING DIAGRAM

** Two Channel UDM (UDM-002) shown for illustration purposes **

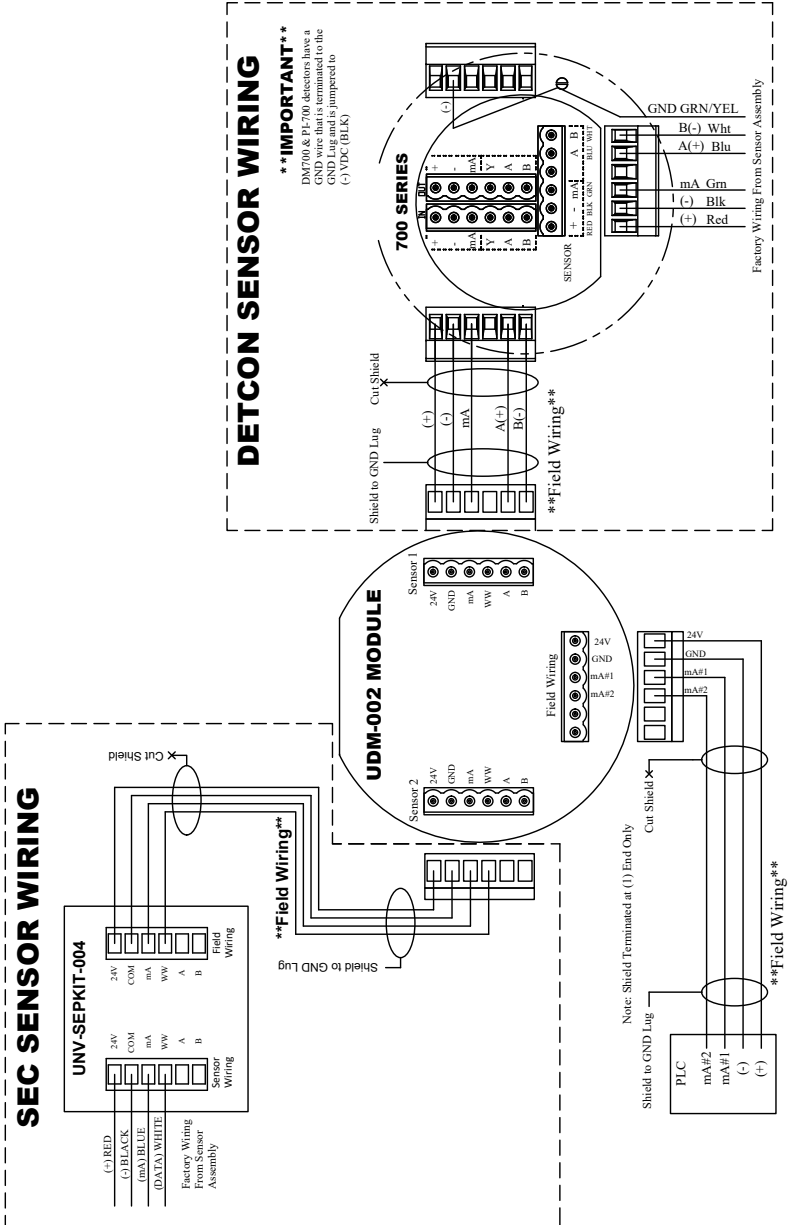

Figure 2: UDM Wiring Diagram

4. Startup / Configuration

4.1 Startup

On power-up of the UDM, it will search for connected detectors. If it finds a detector connected it will upload the detector and parameters to the UDM and display the model connected along with the concentration and gas type (i.e. LEL, H2S, SO2). If no sensor is found during the search, the UDM will stop searching and display COMM FAULT on the display for that channel.

Important Notes

- To initiate a new search, a power recycle must be performed.
- Detcon 700 Series Gas Sensor's must be set to Serial ID = 01 for proper communications with the UDM.
- The UDM does not interrupt or re-create the 4-20mA signal from the attached detector. Therefore, if there is a UDM failure, the attached detector will still send the 4-20mA signal back to the higher-level system and be operational. **i.e. The 4-20mA signal output will not be affected and will be operating properly at the PLC but you will lose the ability to remotely access the detector via the UDM's magnetic interface.**
- If one channel on a dual channel UDM is in COMM FAULT, it has no effect on the other channel.

4.2 Operator Interface

The operator interface of the UDM is very similar to the Detcon Model 700 series detectors. It uses two magnetic programming switches per channel (PGM1/ZERO and PGM2/SPAN) and utilizes the same programming magnet. When activating the magnetic switches on the UDM, you are interfacing the attached detector via various serial communication protocols depending on the make and model of the detector. The UDM interface is designed to mimic the Model 700 series Detcon detector interface even when other brands are connected to give the user consistency when operating the menu structure. However, only the functions deemed critical for normal remote sensor operation are available via the UDM. Other menu functions may be available via the detector itself depending on the make and model connected to the UDM.

4.3 Magnetic Programming Tool

The magnetic programming tool is used to operate the magnetic switches. To activate the magnetic switch, move the magnet over the circle near each PGM marking on the faceplate. The arrow on the display will indicate which switch is being activated.



Figure 3: Programming Magnet

5. Operational Modes

The UDM-MWO has a number of different operating modes such as Normal Operation, Fault Mode, Settings / Program Mode & Calibration Mode.

5.1 Normal Operation

In normal operation, the UDM display continuously shows the current sensor concentration and measurement unit for each channel (i.e. 0% LEL, or 0ppm H₂S). With gas concentrations below 10% of the sensors range the status LED will be green for its respective channel.

At 10% of the detectors range the status LED will flash red to indicate that gas is present.

In normal operation, each 4-20mA current output displays the gas concentration and full-scale range of the corresponding channel.

5.2 Fault Mode – Operation During a Fault Condition

If a channel is actively experiencing any diagnostic faults, a fault message will be present on the display until the channel fault is resolved. The status LED will turn amber and flash.

During a fault condition, the mA output signal for the affected sensor will be a mA reading below 4mA (dependent on the Make and Model of detector attached).

See Section 1.2 for a link to the various compatible detector manuals for more specific details.

5.3 Settings / Program Mode

Settings / Program mode allow you to access existing settings or information about the connected sensor, plus change some setting to suit your application or installation. Some of the information available will depend on the sensor that is connected to the UDM display module.

These menus include:

- View Sensor Status
- Set Autospan Level (If applicable, depends on the detector model connected) Display ON/OFF
- Service Menu

5.3.1 View Sensor Status Menu

The “**View Sensor Status**” menu displays some settings parameters of the connected detectors and will vary depending on the Make and Model of the detector attached.

To access the “**View Sensor Status**” menu:

1. Hold the magnet over PGM2, of the channel you want to access.
2. When the arrow prompt appears hold the magnet continuously for 3 seconds, “**View Sensor Status**” text will scroll.
3. When the “**View Sensor Status**” text scrolls, hold the magnet over PGM2.
4. When the arrow prompt appears, hold continuously again for approximately 3 seconds. This will bring you into the “**View Sensor Status**” menu and the display will start to scroll the complete list of sensor status parameters sequentially. You can now remove the magnet.
5. When the sensor status list sequence is complete, the display will revert to the “**View Sensor Status**” text scroll and after a few seconds revert to normal operation.

Detcon Model 700 Series Sensors Display:

- Sensor Range
- Autospan Level
- Sensor Life
- Model Type
- Days Since Last Cal
- 4-20mA Output
- Input Voltage
- Sensor Temperature
- Note: Sensor Diagnostics (varies by sensor type)

Sensor Electronics Millenium Series Detectors Display:

- Sensor Range
- Autospan Level
- Gas Curve
- Model Type
- Sensor Temperature

Note: Sensor Diagnostics (varies by sensor type)

Sensor Electronics 3000 Series Detectors Display:

- Sensor Range
- Autospan Level
- Model Type
- Input Voltage
- Sensor Temperature

Note: Sensor Diagnostics (varies by sensor type)

5.3.2 Set Autospan Level Menu *(Not applicable to SEC Millenium Series)*

“Set Autospan Level” is used to set the span gas concentration level that is being used to calibrate the sensor. This adjustable level is dependant on the detector attached. Refer to the applicable detector manual. The current setting can be viewed in “View Sensor Status”, but you can enter the “Set Autospan Level” menu to make changes.

To access the “Auto Span Level” menu:

1. Hold the magnet over PGM2, of the channel you want to access. When the arrow prompt appears hold the magnet continuously for 3 seconds, “View Sensor Status” text will scroll.
2. When the “View Sensor Status” text scrolls, hold the magnet over PGM2 and as soon as the arrow prompt appears, remove the magnet away.
3. When the “View Alarm Settings” text scrolls, hold the magnet over PGM2 and as soon as the arrow prompt appears, remove the magnet away.
4. When the “Set Autospan Level” text scrolls, hold the magnet over PGM2.
5. When the arrow prompt appears, hold continuously again for approximately 3 seconds. This will bring you into the “Set Autospan Level” menu and display the current span gas level setting.
6. Swipe the magnet momentarily over PGM 1 to increase or PGM 2 to decrease the value until the correct span level is displayed.
7. Hold the magnet over PGM 2 for 3 seconds to accept the new value.
8. The display will show “Level Saved”.
9. The display will revert to the “Set Autospan Level” text scroll and after a few seconds revert to normal operation.

Note: If the changes are not saved, they will revert to the previous values.

5.3.3 Turning the Display OFF & ON

The UDM display can be switched into OFF, individually for each channel. This feature can be useful when using a dual channel UDM with a single detector. The procedure will vary depending on if the UDM is connected to a detector or not.

To access the “**Display ON / OFF**” menu:

1. Hold the magnet over PGM2, of the channel you want to access. When the arrow prompt appears hold the magnet continuously for 3 seconds, “**View Sensor Status**” text will scroll if there is a sensor connected. If the display is in a “**No Sensor Found!!**” fault condition, the “**Display ON/OFF**” menu will appear, proceed to step 4.
2. When the “**View Sensor Status**” text scrolls, hold the magnet over PGM2 and as soon as the arrow prompt appears, remove the magnet away.
3. Continue this procedure until you reach the “**Display ON/OFF**” menu.
4. When you reach the menu and the “**Display ON/OFF**” text scrolls, hold the magnet over PGM2.
5. When the arrow prompt appears, hold continuously again for approximately 3 seconds. This will bring you into the “**Display ON/OFF**” menu. “**Display ON**” will be shown on the display.
6. Toggle the “**Display ON**” to “**Display OFF**” by placing and removing the magnet on PGM2.
7. Hold the magnet on PGM2 for 3 seconds to save. Remove the magnet and wait for the display to return to normal operation where “**DISPLAY OFF**” will be displayed.

Note: If you have a “**No Sensor Found!!**” fault, due to a channel not being used, the display for that channel should be turned to OFF mode.

Turning the display ON from OFF mode by following these steps:

1. Hold the magnet over PGM2, of the channel you want to turn the display “**ON**” for.
2. When the arrow prompt appears, hold continuously again for approximately 3 seconds. This will bring you into the “**Display ON/OFF**” menu. “**Display OFF**” will be shown on the display.
3. Once you have the display reading “**Display ON**”, hold the magnet on PGM2 for 3 seconds to save. Remove the magnet and wait for the display to return to normal operation. The UDM will reboot, search and connect to the existing detector(s).



Warning

- Turning the display to “**OFF**” DOES NOT interrupt or alter the 4-20 mA signal or the operational characteristics of any connected detector if 3, 4 or 5 wires are being used for sensor separation.

5.3.4 Service Menu

The “**Service Menu**” allows the user access to some diagnostic menus to help trouble- shoot field and operational issues. It is available from firmware version 2.13 onward. It is made up of the following sub menus:

- View Comm Errors
- Restore Sensor Defaults
- View Event Logs
- Erase Event Logs

To access the “**Service Menu**”:

1. Hold the magnet over PGM2, of the channel you want to access. When the arrow prompt appears hold the magnet continuously for 3 seconds, “**View Sensor Status**” text will scroll.
2. When the “**View Sensor Status**” text scrolls, hold the magnet over PGM2 and as soon as the arrow prompt appears, remove the magnet away.
3. When the “**View Alarm Settings**” text scrolls, hold the magnet over PGM2 and as soon as the arrow prompt appears, remove the magnet away.
4. Continue this procedure until you reach “**Service Menu**”.
5. When the arrow prompt appears, hold continuously again for 3 seconds. This will bring you into the “**Service Menu**” menu.
6. Once you enter the “**Service Menu**”, you will have access to the sub menus listed above.

Note: To access the sub menus, follow the same procedure used to navigate the main menu.

5.3.4.1 View Comm Errors

This sub menu allows the user to see if any communication issues are happening between the sensor and the UDM module. Note, this log will automatically erase after a power recycle.

1. To access the “**View Comm Errors**” from the “**Service Menu**”, hold the magnet over PGM2. When the arrow prompt appears hold the magnet continuously for 3 seconds, “**View Comm Errors**” text will scroll.
2. When the “**View Comm Errors**” text scrolls, hold the magnet over PGM2. When the arrow prompt appears hold the magnet continuously for 3 seconds.
3. The display will then show the number of communication errors, if any since the last power cycle.
4. The UDM will automatically bring you back to the “**Service Menu**” and if nothing else is selected, back to normal operation.

5.3.4.2 Restore Sensor Defaults (*Not applicable to SEC 3000 Series*)

This menu allows the user to reset the sensor that is connected to the UDM display, back to factory settings.

1. To access the “**Restore Sensor Defaults**” from the “**Service Menu**”, Hold the magnet over PGM2. When the arrow prompt appears hold the magnet continuously for 3 seconds, “**View Comm Errors**” text will scroll.
2. When the “**View Comm Errors**” text scrolls, hold the magnet over PGM2 and as soon as the arrow prompt appears, remove the magnet away, “**Restore Defaults**” text will scroll.
3. When the “**Restore Defaults**” text scrolls, hold the magnet over PGM2. When the arrow prompt appears hold the magnet continuously for 3 seconds.
4. The display will ask for a “**Yes Restore**” or “**No Restore**” decision on restoring defaults. You can change from “**No Restore**” to “**Yes Restore**” by momentarily touching PGM1 of PGM2.
5. Once the decision is made, hold the magnet on PGM2 to save. If no selection is made the menu will time out return to the “**Service Menu**” and then to normal operation. If “**No Restore**” was selected, the display will say, “**Defaults Not Restored**” and return to the “**Restore Sensor Defaults**”, then to the “**Service Menu**” and then to normal operation. If “**Yes Restore**” was selected, the display will say “**Defaults Restored**”, and the channel will then show that it is “**Resetting**”. Next the UDM will complete a recycle of power to all channels.

WARNING: *Ensure all channels are in bypass before restoring any channel to avoid a low mA output value or Fault Relay state change (if applicable).*

5.3.4.3 View Event Logs

This menu allows the user to see any of the past 100 alarm of fault events in a chronological order. They are not time and date stamped; however, you can scroll from the most recent to oldest events. Once 100 events are reached, any new events logged will erase the oldest events (first in, first out).

1. To access the “**View Event Logs**” from the “**Service Menu**”, Hold the magnet over PGM2. When the arrow prompt appears hold the magnet continuously for 3 seconds, “**View Comm Errors**” text will scroll.
2. When the “**View Comm Errors**” text scrolls, hold the magnet over PGM2 and as soon as the arrow prompt appears, remove the magnet away, “**Restore Defaults**” text will scroll.
3. When the “**Restore Defaults**” text scrolls, hold the magnet over PGM2 and as soon as the arrow prompt appears, remove the magnet away, “**View Event Logs**” text will scroll.
4. When the “**View Event Logs**” text scrolls, hold the magnet over PGM2. When the arrow prompt appears hold the magnet continuously for 3 seconds.
5. Once in this menu you can scroll through the events, if any are there, by using PGM1 and PGM2. Once the user is done scrolling through the events, the menu will time out automatically bring you back to the “**View Event Logs**” menu, then the “**Service Menu**” and if nothing else is selected, and then back to normal operation.

5.3.4.4 Erase Event Logs

This menu allows the user to erase the event log.

1. To access the “**Erase Event Logs**” from the “**Service Menu**”, Hold the magnet over PGM2. When the arrow prompt appears hold the magnet continuously for 3 seconds, “**View Comm Errors**” text will scroll.
2. When the “**View Comm Errors**” text scrolls, hold the magnet over PGM2 and as soon as the arrow prompt appears, remove the magnet away, “**Restore Defaults**” text will scroll.
3. When the “**Restore Defaults**” text scrolls, hold the magnet over PGM2 and as soon as the arrow prompt appears, remove the magnet away, “**View Event Logs**” text will scroll.
4. When the “**View Event Logs**” text scrolls, hold the magnet over PGM2 and as soon as the arrow prompt appears, remove the magnet away, “**Erase Event Logs**” text will scroll.
5. When the “**Erase Event Logs**” text scrolls, hold the magnet over PGM2. When the arrow prompt appears hold the magnet continuously for 3 seconds.
6. The display will ask for a “**Yes Erase**” or “**No Erase**” decision on erasing the log. You can change from “**No Erase**” to “**Yes Erase**” by momentarily touching PGM1 or PGM2.
7. Once the decision is made, hold the magnet on PGM2 to save. If no selection is made the menu will time out return to the “**Erase Logs**” menu, then the “**Service Menu**” and then to normal operation. If “**No Erase**” was selected, the display will say, “**Logs Not Erased**” and return to the “**Erase Logs**” menu, then to the “**Service Menu**” and then to normal operation. If “**Yes Erase**” was selected, the display will say “**Logs Erased**”, and return to the “**Erase Logs**” menu, then to the “**Service Menu**” and then to normal operation.

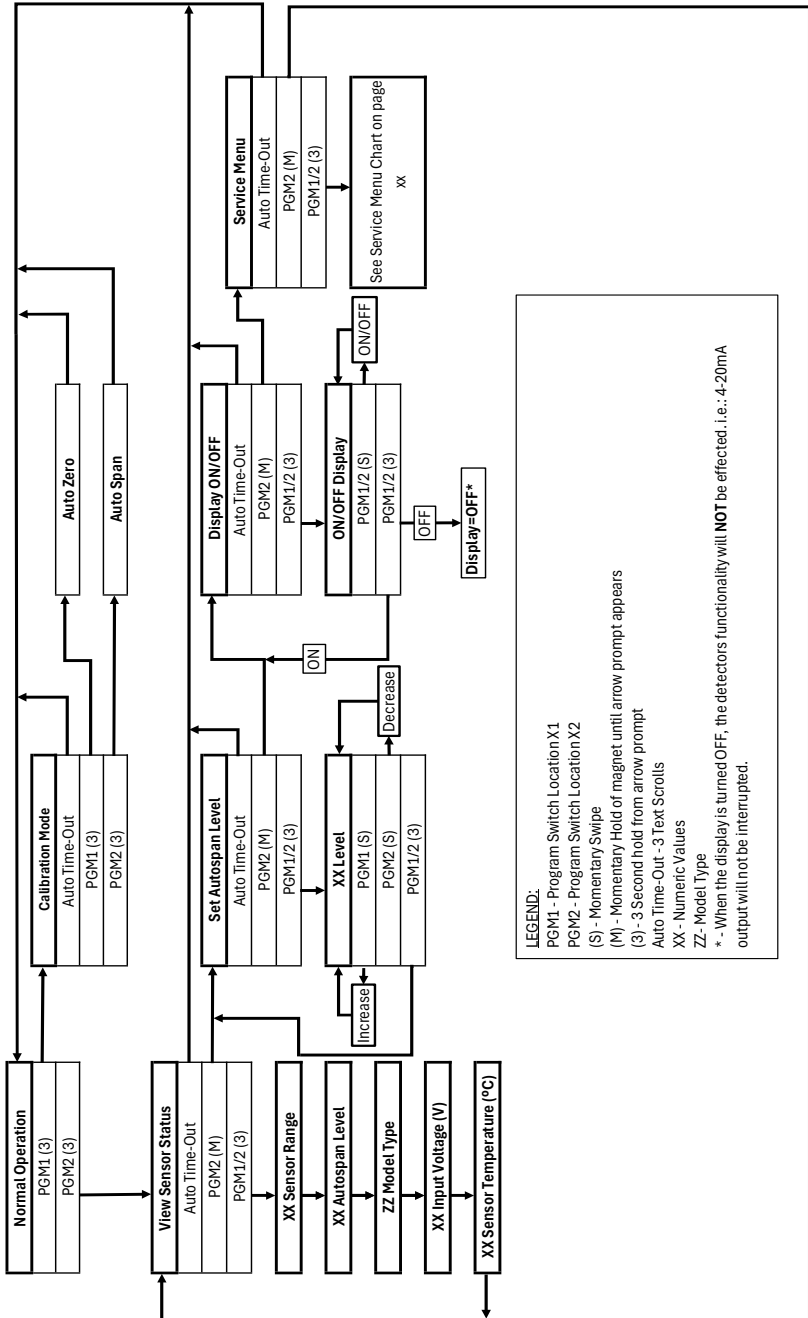

LEGEND:
 PGM1 - Program Switch Location X1
 PGM2 - Program Switch Location X2
 (S) - Momentary Swipe
 (M) - Momentary Hold of magnet until arrow prompt appears
 (3) - 3 Second hold from arrow prompt
 Auto Time-Out - 3 Text Scrolls
 XX - Numeric Values
 ZZ - Model Type
 * - When the display is turned OFF, the detectors functionality will NOT be effected, i.e.: 4-20mA output will not be interrupted.

Figure 4: SEC Millennium Series Programming Flowchart

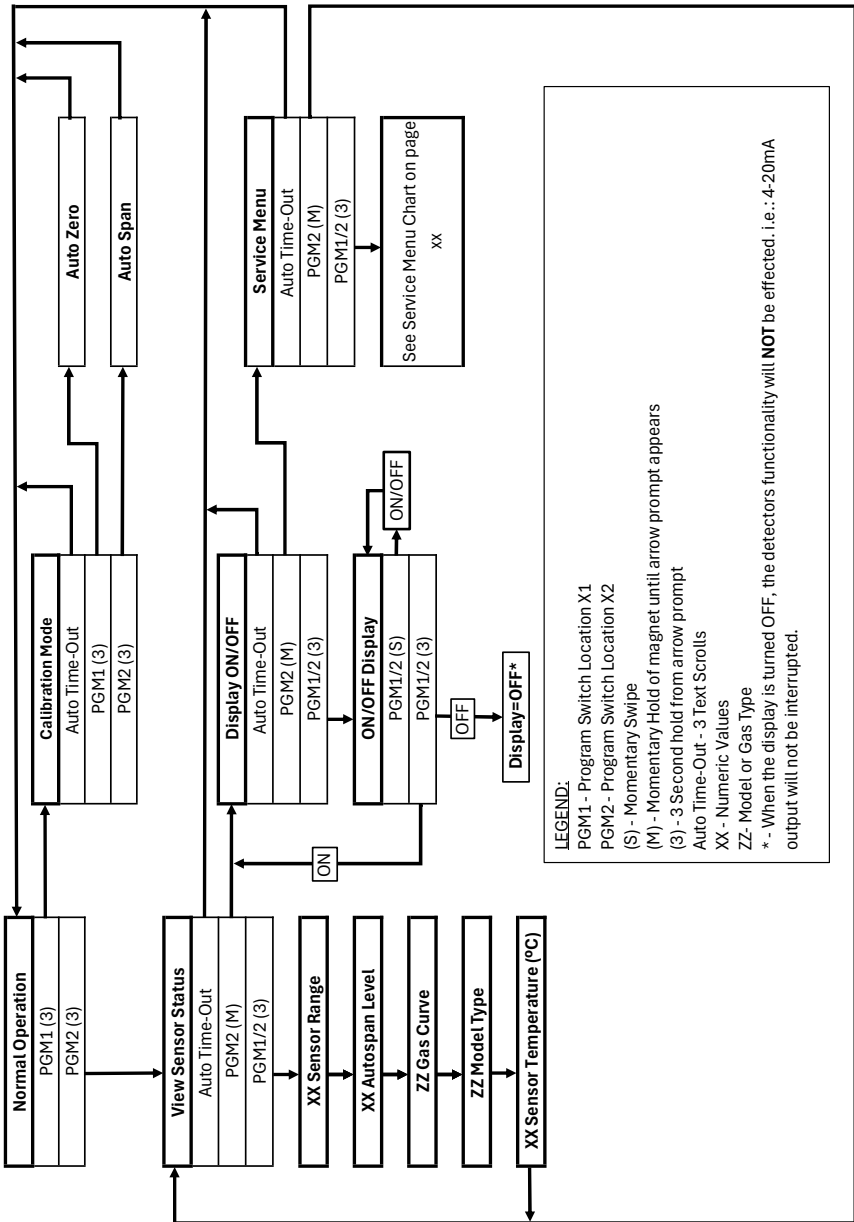

Figure 5: SEC 3000 Series Programming Flowchart

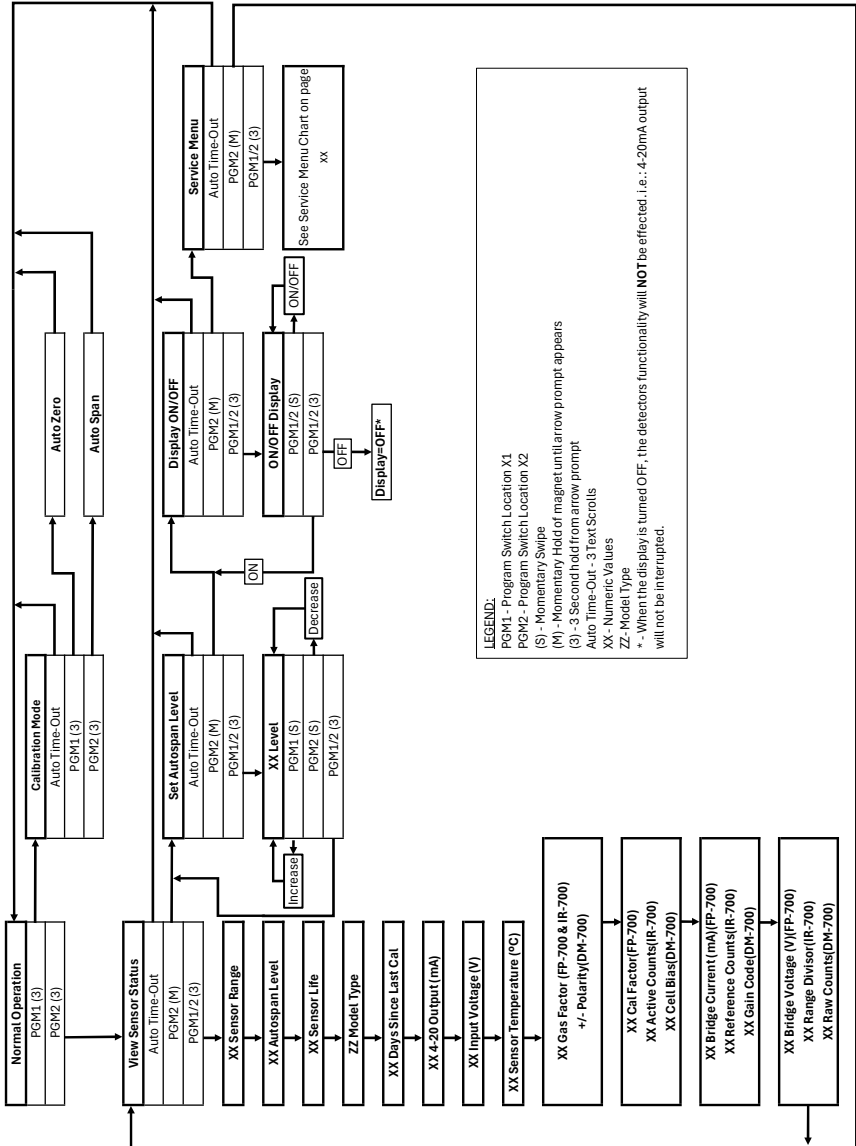
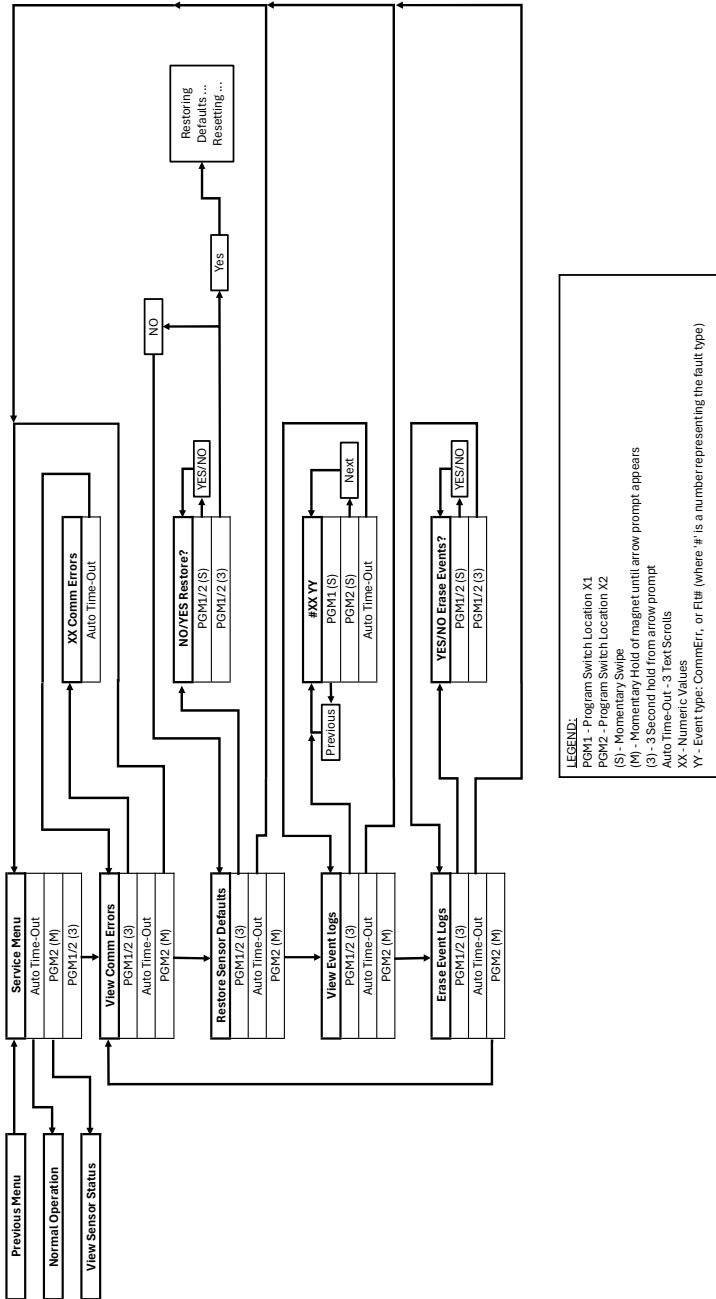

Figure 6: Detcon 700 Series Programming Flow Chart



LEGEND:
 PGM1 - Program Switch Location X1
 PGM2 - Program Switch Location X2
 (S) - Momentary/Swipe
 (M) - Momentary/Hold of magnet until arrow prompt appears
 (C) - 3 Second hold from arrow prompt
 Auto Time-Out - 3 Text Scrolls
 XX - Numeric Values
 YY - Event type: CommErr, or FI# (where # is a number representing the fault type)

Figure 7: UDM-Service Menu Programming Flow Chart

5.4 Calibration Mode (Zero & Span)

When the user enters the calibration mode to complete a “Zero” or “Span”, the applicable detector will drop its mA output below 4mA until the calibration is completed and the detector is back into normal operation. See figures 7, 8 or 9.

5.4.1 Zero Calibration

A zero calibration can be performed on all sensors by accessing the UDM calibration menu. Intervals for zero calibration are dependent on the attached make and model of detector. Details regarding the Zero calibration frequency can be found in the applicable detector manual.

To access the Zero Calibration menu:

1. Hold the magnet over PGM1, of the channel you want to access.
2. When the arrow prompt appears hold the magnet continuously for 3 seconds, “**PGM1 = Zero PGM2 = Span**” text will scroll.
3. Hold the magnet on PGM1 and when the arrow appears, continue to hold for 3 seconds until the zero calibration is started and “**Setting Zero...**” scrolls on the display.
4. Once the zero calibration is finished, the display will say “**Zero Cal Complete**” and the detector will return to normal operation.

Note: During zero calibration, the detector output will either go to 2mA or stay at 4mA depending on the detector attached.

5.4.2 Span Calibration

A span calibration can be performed on all sensors by accessing the UDM calibration menu. Span calibration frequencies are dependent on the attached make and model of detector. Details regarding the span calibration frequency can be found in the applicable detector manual.

To access the “**Span Calibration**” menu:

1. Hold the magnet over PGM1, of the channel you want to access. When the arrow prompt appears hold the magnet continuously for 3 seconds, “**PGM1 = Zero PGM2 = Span**” text will scroll.
2. Hold the magnet on PGM2 and when the arrow appears, continue to hold for 3 seconds until span calibration is started and “**Setting Span...**” scrolls on the display.
3. When “**Apply Gas**” scrolls on the display, apply to the required span gas to the detector and wait for the UDM-MWO to advise if the calibration is accepted.
4. If a calibration is successful, the display will “**Remove Gas**”.
5. Once gas is removed and the gas level returns close to “**0**” on the display, the display will say “**Span Complete**”. The detector will return to normal operation.

Note: If a calibration is not completed the sensor will go into fault and the display will state “**-11 Cal Fault (15)**”

Note: During the span calibration, the detector output will go to 2mA until calibration is finished.

6. Maintenance and Service Personnel Activities

Service and maintenance activities should be completed according to individual manufacturer specification and should be performed by trained individuals. Any other required service or maintenance related activity shall only be performed by a Factory-Certified technician.

7. Troubleshooting Guide

7.1 General Troubleshooting

7.1.1 Communication Fault (COMM Fault):

- Is the channel being used? If no detector is connected to that channel, turn off the display for that channel only to avoid getting the COMM FAULT message. See Section 5.3.4.
- Note: If one channel on a dual channel UDM is in COMM FAULT, it has no effect on the other channel.
- Check that the terminal block is correctly seated and the wiring to the UDM module is correct for the compatible detector.
- For Detcon Model 700 Series Gas Sensors, ensure that the Serial ID is set to address “01” to ensure proper communications with the UDM. The address for the Model 700 is set by accessing the Model 700 menu.
- Check wiring connections and if all connections are good, recycle power to restart the UDM detector searching.

7.2 Detcon Sensor Specific Troubleshooting

7.2.1 0.00mA Output / -11 on the display:

This indicates that the Detcon gas detector is in a fault condition. The specific fault condition will scroll across the UDM or can be viewed on the Detcon (ITM) by touching the magnet momentarily on PGM-1 or PGM-2. Refer to the Detcon specific manual for the specific fault condition and resolution.

7.2.2 “WAIT” continuously scrolling on the DETCON display:

The 4-20mA output is not connected so the detector cannot complete its startup sequence. Check the 4-20mA loop and ensure you are getting the correct 4-20mA output signal at the PLC or DCS, etc.

If the wiring is connected properly but there is no 4-20mA signal being measured at the PLC or DCS, continue with the following steps:

- Break the loop in the following places and measure the 4-20mA output from that point to common of the power supply:
- Inside the Detcon separation kit from the green wire (4-20mA) to the black wire (common). If the 4-20mA is measuring correctly, reconnect the loop and proceed. If not, call support for further steps.
- On the field wiring side of the separation kit terminal block (TPB) break the loop and measure from the output 4-20mA terminal to the common terminal. If the 4-20mA is measuring correctly, reconnect the loop and proceed. If not, the TPB is most likely blown and needs to be replaced.

Refer to the Detcon model specific manual for the other fault condition and resolution.

Figure 7: Detcon Sensor Specific Troubleshooting

Event Log Fault Codes – Detcon Sensors			
Fault Number	Fault Name	Description	Action
33	180 Day Cal Reminder	Unit has not been span calibrated for more than 180 days	Complete a span calibration and recycle power after it is complete.
34	Temperature Fault	Ambient temperature that is outside of the -40°C to +75°C	Check Temperature to ensure it is within the detector operating range. If it is, call for additional troubleshooting
35	mA Fault	4-20mA output loop of the detector is not functional	Check the 4-20mA output loop to ensure it is connected. For the Aux mA output of the UDM-MWO, see section 5.3.7. of the manual. For the standard mA outputs of the UDM-MWO when connected to a Detcon detector, connect the output loop of output(s). If the mA output is not being used, it needs to be jumpered to the common terminal. Call for more details.
36	Voltage Fault	input voltage of the detector is outside of the 11.5-28 VDC range	Confirm the voltage is between 11.5-28Vdc at the sensor input terminals. If it is, call for additional troubleshooting.
37	Memory Fault	Detector has a failure in saving new data to memory	Call for additional troubleshooting
38	Processor Fault	Detector has unrecoverable run-time errors	Call for additional troubleshooting
39	Clearing Fault	Detector failed the signal stability criteria during AutoSpan sequence	Gas did not clear from the sensor after the calibration. Try a new calibration and purge the sensor after calibration is complete.
40	Stability Fault	Detector failed the signal stability criteria during AutoSpan sequence	Try a new span calibration. If the fault is still present, replace the sensor.
41	Range Fault	Detector failed the minimum signal change criteria during AutoSpan sequence	Try a new span calibration. If the fault is still present, replace the sensor.
42	Sensor Fault	Plug-in sensor or the supporting electronics failed to meet the required minimum or maximum working signal parameters	Call for additional troubleshooting
43	Zero Fault	If the detector drifts below -10% of range	Complete a new zero & span calibration
44	Sensor Fault 2	Plug-in sensor cell or the supporting electronics failed to meet the required minimum or maximum working signal parameters	Call for additional troubleshooting
45	In Calibration	Detector is in calibration	If the detector is not in calibration when this fault shows up, call for additional troubleshooting
46	Communication Error	Communication error between the detector and plug-in sensor cell	Call for additional troubleshooting
47	General Fault	Unknown fault	Check the supply voltage to ensure it is within the detector operating range. If it is, call for additional troubleshooting

Figure 8: Sensor Electronics Corp Sensor Specific Troubleshooting

Event Log Fault Codes – SEC Sensors			
Fault Number	Fault Name	Description	Action
1	EEPROM Header Byte	EEPROM does not have correct header byte stored	Call for additional troubleshooting
2	EEPROM Checksum	Checksum byte from EEPROM does not match calculated checksum on latest EEPROM read	Call for additional troubleshooting
3	No Zero Yet	Unit has yet to be zero calibrated	Complete a new zero calibration using zero gas
4	No Span Yet	Unit has yet to be spanned	Complete a new span calibration
5	Zero Values	Zero values are out of specification limits	Call for additional troubleshooting
6	4-20 Calibration 1	When searching for >4vdc level during the 4-20ma calibration procedure, it was unsuccessful in the first three attempts	Call for additional troubleshooting
7	4-20 Calibration 2	When searching for the exact 4vdc level during the 4-20ma calibration procedure, it was unsuccessful in the first four attempts.	Call for additional troubleshooting
8	Signal High	When the signal level is greater than 4.75vdc at the time it is read during the AGC procedure.	Complete a new zero calibration using zero gas. Also, Check response and perform a span calibration if required.
9	4VDC Reference Low	The internal reference voltage is too low	Confirm the voltage is between 18-30 Vdc at the sensor input terminals. If it is, call for additional troubleshooting.
10	4VDC Reference High	The internal reference voltage is too high	Confirm the voltage is between 18-30 Vdc at the sensor input terminals. If it is, call for additional troubleshooting.
11	Balance Pot Max	The balance digital potentiometer reaches the maximum predetermined value during the unit calibration procedure	Complete a new zero calibration using zero gas
12	Balance Pot Min	The balance digital potentiometer reaches the minimum predetermined value during the unit calibration procedure	Complete a new zero calibration using zero gas
13	AGC Pot Max	The AGC digital potentiometer reaches the maximum predetermined value during the unit AGC procedure.	Millenium series specific fault - Clean the internal optics. See Section V of the Millenium manual for details.
14	AGC Pot Min	The AGC digital potentiometer reaches the minimum predetermined value during the unit AGC procedure.	Millenium series specific fault - Clean the internal optics. See Section V of the Millenium manual for details.
15	Span Pot Max	The span digital potentiometer reaches the maximum predetermined value during the unit span procedure.	Complete a new span calibration - ensure span gas concentration is correct for the sensor range. - use a 1.0LPM minimum regulator - if the sensor location has moving air flow, you may need to stop the air flow from carrying away the span gas: Millenium IR Detector - you may need a calibration sleeve or make shift wind block to stop wind from entering the side holes on the housing baffle. SEC3000 Series - you may need a calibration adapter only vs the calibration / splash guard adapter or a make shift wind block to stop wind from entering the side slots on the existing calibration / splash guard adapter.
16	Span Pot Min	The span digital potentiometer reaches the minimum predetermined value during the unit span procedure.	Complete a new span calibration - ensure span gas concentration is correct for the sensor range. - use a 1.0LPM minimum regulator - if the sensor location has moving air flow, you may need to stop the air flow from carrying away the span gas: Millenium IR Detector - you may need a calibration sleeve or make shift wind block to stop wind from entering the side holes on the housing baffle. SEC3000 Series - you may need a calibration adapter only vs the calibration / splash guard adapter or a make shift wind block to stop wind from entering the side slots on the existing calibration / splash guard adapter.
17	No Hot Zero Yet	Unit has yet to be zeroed while Hot	Call for additional troubleshooting
18	No Cool Zero Yet	Unit has yet to be zeroed while Cool	Call for additional troubleshooting
19	Unit Temp High	Unit temperature is over the specified upper limit	Check Temperature to ensure it is within the detector operating range. If it is, call for additional troubleshooting
20	Unit Temp Low	Unit temperature under the specified lower limit	Check Temperature to ensure it is within the detector operating range. If it is, call for additional troubleshooting
21	Analytical Range	Insufficient Analog Range during spanning	SEC3000 series specific fault - Perform a zero and span calibration
22	No Table Yet	Unit has yet to download a table via the PC and Comm_Link	SEC3000 series specific fault - Perform a zero and span calibration
23	Span No Longer Valid	Range has been changed	Calibration Required
24	Span Pot Overflow	Not enough Span pot room for temperature comp. (Span Gain too high)	Either the sensor has no life, bad span gas or bad gas flow. Try another calibration
25	24VDC Low	24VDC too low	Confirm the voltage is between 18-30 Vdc at the sensor input terminals. If it is, call for additional troubleshooting.
26	24VDC High	24VDC too high	Check the supply voltage to ensure it is within the detector operating range. If it is, call for additional troubleshooting
27	Pressure Fault	No Pressure Sensor Input	Check the supply voltage to ensure it is within the detector operating range. If it is, call for additional troubleshooting

8. Specifications

Inputs

Detcon Model 700 Gas Detectors (except DM-700-O2)
Sensor Electronics Millenium Detectors
Sensor Electronics 3000 Series Detectors (except SEC3000-O2)
*Detector Models to be verified for functionality at time of quote
Outputs
4-20mA (3 wire device configuration) from each available channel

Input Voltage

10.5-30VDC (determined by voltage of attached detector(s))

Power Consumption *(excluding attached gas sensors)*

< 0.5 Watts at 24VDC (Normal)

Operating Temperature

-40°C to +75°C

Electrical Classification

Class I, Division 1, Group B, C, D T4 (Seals Required)
Ex db IIB T4 Gb (Seals Required)
Class I, Zone 1, AEx db IIB T4 Gb (Seals Required)
Class I, Division 2, Group A, B, C, D T4 (No Seals Required)
Class I, Zone 2, Group IIC T4 (No Seals Required)
-40°C ≤ Tamb ≤ 85°C

Performance Certifications *(when used with combustible gas detectors)*

Conforms to CSA C22.2 No.152 M(1984) R2016 with the following gas detectors:

- Universal Display Module UDM-001 with Detcon Gas sensor IR700 and FP-700.
- Universal Display Module UDM-002 with Detcon Gas sensor IR700 and FP-700.
- Universal Display Module UDM-001 with Sensor Electronics Millenium Gas Sensor.
- Universal Display Module UDM-002 with Sensor Electronics Millenium Gas Sensor.

Conforms to CSA C22.2 No. 60079-29-1:17/A1:22 (R2022) and UL 60079-29-1 Ed: 2 with the following gas detectors:

- Universal Display Module UDM-001 with Sensor Electronics SEC Millenium Hawk Infrared Gas Detector.
- Universal Display Module UDM-002 with Sensor Electronics SEC Millenium Hawk Infrared Gas Detector.

Enclosure Classification

NEMA4X, IP66/67

9. Customer Support and Service Policy

Protek Safety & Controls Ltd.
#10, 1710 – 27th Ave NE
Calgary, AB T2E7E1

All Technical Service and Repair requests should be sent to Protek’s Service Department by calling 403-668-6869 or emailing service@proteksc.com. RMA numbers should be obtained from the Protek Service Department prior to equipment being returned. For on-line technical service, have the model number, part number, and serial number of product(s) in question available.

All Sales requests (including spare parts purchase) should be sent to Protek’s Safety & Controls Ltd. by calling 403-668-6869 or emailing sales@proteksc.com.

10. Warranty Notice

Protek Safety & Controls Ltd. warrants, under intended normal use, each new UDM- MWO module to be free from defects in material and workmanship for a period of two years from the date of shipment to the original purchaser. All warranties and service policies are FOB Protek Safety & Controls Ltd., Calgary Alberta.

Terms & Conditions:

- Shipping point is FOB Protek Calgary.
- Net payment is due within 30 days of invoice.
- Protek Safety & Controls Ltd. reserves the right to refund the original purchase price in lieu of UDM-MWO replacement.

Except for the express warranty stated above, Protek Safety & Controls Ltd. disclaims all warranties regarding the products sold. Including all implied warranties of merchantability and fitness and the express warranties stated herein are in lieu of all obligations or liabilities on the part of Protek Safety & Controls Ltd. for damages including, but not limited to, consequential damages arising out of, or in connection with, the performance of the product.

11 Revision Log

Revision	Date	Changes made	Approval
0	2021/11/25	Initial Release	TM
1	2021/12/14	Add content, edits	TM
2	2022/06/15	Updated wiring Diagrams for Detcon product	TM
3	2023/01/24	Updated certification details	TM
4	2023/02/13	Updated certification details	TM
5	2023/02/15	Update specification	TM
6	2023/08/15	Certification Updated, minor edits	TM
7	2023/10/23	Minor Updates, added to section 7.0	TM
8	2024/03/08	Certification Details Updated	TM
9	2024/03/24	Minor edits	TM
10	2024/11/07	Minor edits	TM
11	2025/01/29	Major Update incl. Service Menu Addition	TM



Our promise is to always do what is right in order to exceed expectations and deliver for our customer - EVERY TIME



Protek Safety & Controls Ltd.
#10, 1715 – 27th Ave NE
Calgary, AB T2E 7E1
Ph.403-668-6869 / Fax 403-668-6865
www.proteksc.com